



■ Features

- Dual IR sensing method reducing false alarms
- 25 to 35m long detection distance
- Max 100° wide detection angle
- OMNIVIEW™ 360° LED
- Flexible installation on ceiling or wall with an adjustable mounting bracket
- Compatible with Nittan B3-J, 3T and EVA-UB4 bases
- Low standby current - typical 110μA
- Japanese type approval model
- Available as a replacement for predecessors such as 2VA1-P and 2RA1-P
- Improved sensor resistance against shock, humidity and external noise

■ Description

The PR2B-P-009A is a conventional flame detector designed to respond to the presence of a flame, by using the dual infrared radiation, IR sensing method.

The PR2B-P-009A detects flame in large space or high-ceiling areas, such as atrium or gymnasium where spot type of heat/smoke detector is difficult to cover for detecting fire.

The detector effectively responds to small fire such occurring from machine which uses combustible sources and chemicals.

■ Applications

- Large space, high ceiling building
- Gymnasiums
- Atriums
- Theaters
- Warehouse
- Aircraft hangars
- Warehouse of hazardous materials, etc. (Excluding explosion-proof areas)

■ Detection range

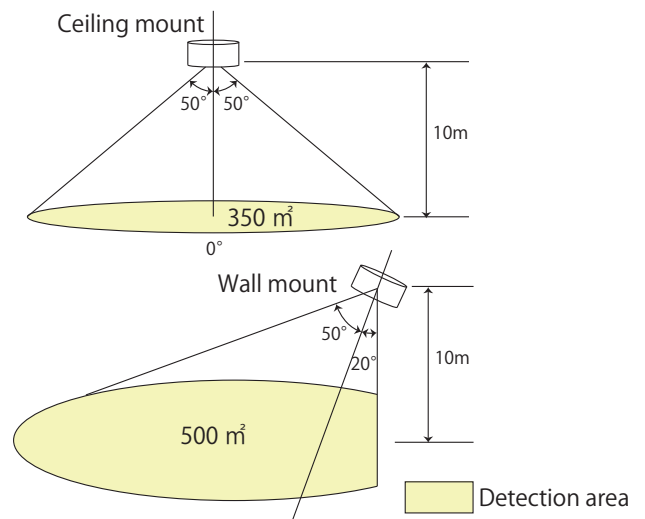
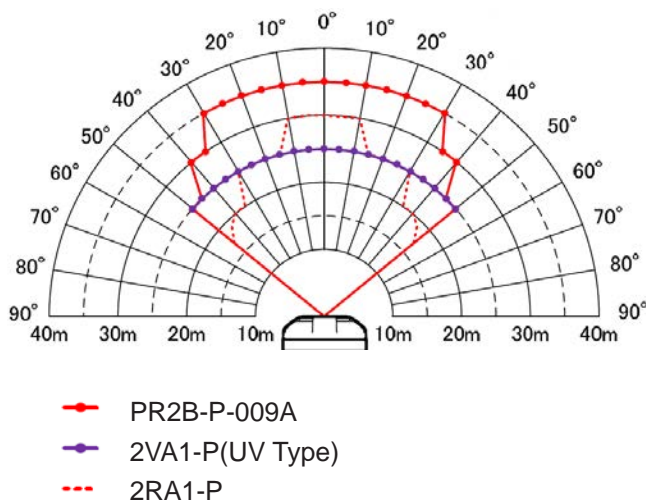

■ Dual Wavelength System

All of objects, which have temperature, emit the infrared radiation. However, the emitted from those objects do not have the characteristic spectral peak what the flame emitting infrared radiation has. The PR2B-P-009A has two sensors and the second sensor is used to utilize those spectral peak differences to respond to fire. The infrared radiation emitted by object or flame is checked by the sensors and compared by next method to confirm real fire or not. The PR2B-P-009A becomes alarm by flame when output of the first wavelength which is detected by the first sensor is larger than that of the second wavelength which is detected by the second sensor.

On the other hand, if the first wavelength level is less than the second wavelength level, the PR2B-P-009A is not activated. By this method, the PR2B-P-009A can discriminate whether the heat source is emitted by objects or flame, and it is possible to prevent from false alarm.

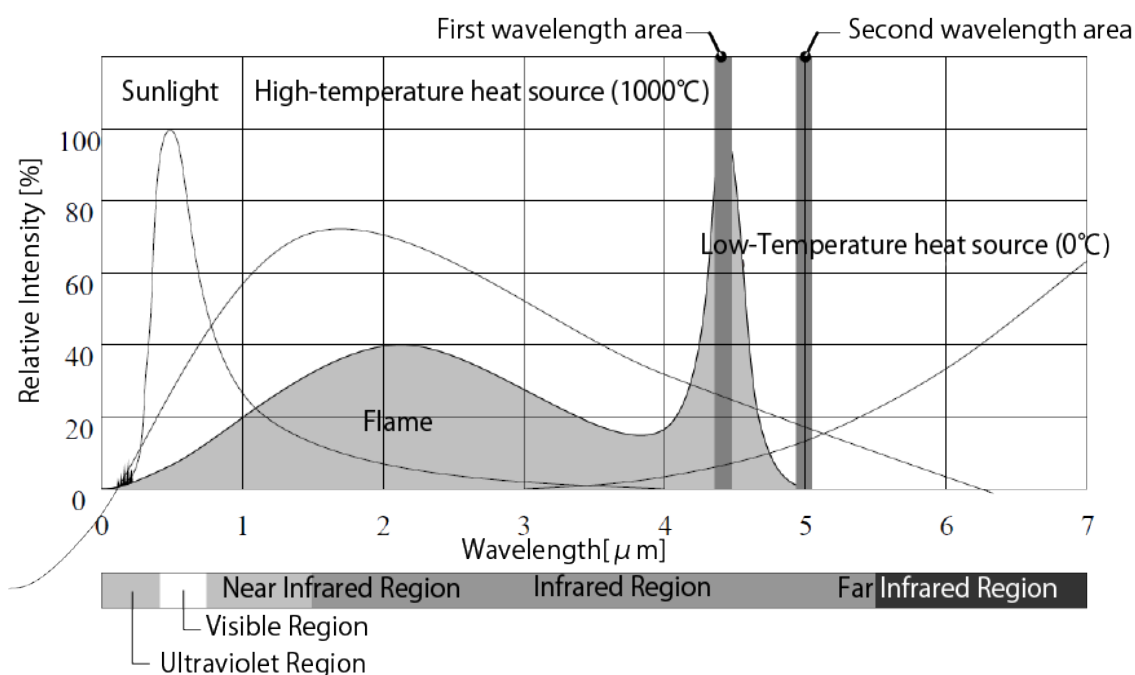

■ Remote Test Function

Remote test function is available by using a dedicated remote tester MTT. In case of the tested PR2B-P-009A has either the sensor contamination by dust or failure, that can be found by operating the MTT and checking the detector.



NOT TO BE USED FOR INSTALLATION PURPOSES.

Nittan reserves the right to make changes at any time without notice in prices, colours, materials, components, equipment, specifications and models and also to discontinue models.

PR2B-P-009A-DAT-00

Rev.0

■ Wiring Information

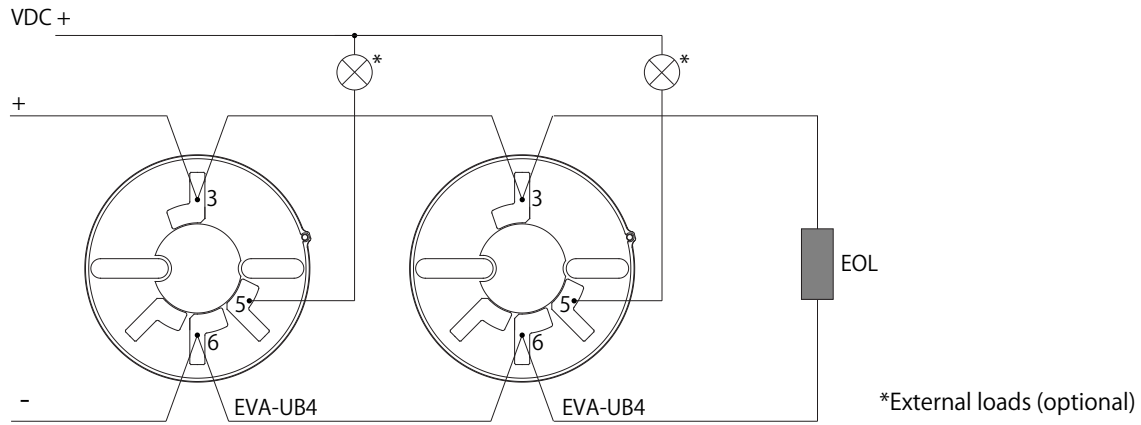

■ Dimension

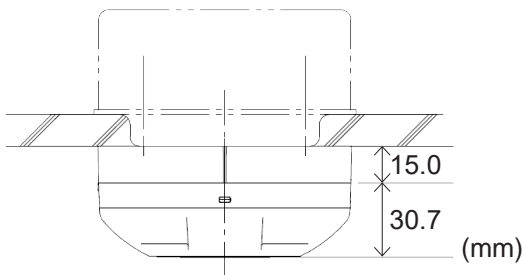

Side-view (PR2B-P-009A with EVA-UB4)

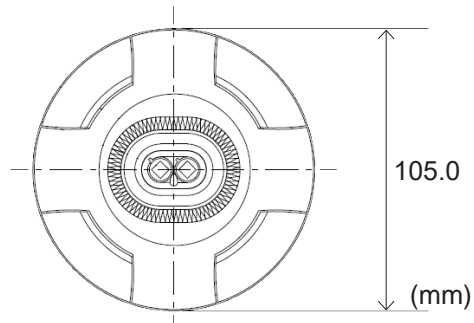

Front-view

■ Specifications

Specifications	PR2B-P-009A
Part number	PR2B-P-009A
Description	Conventional dual IR flame detector
Input voltage	DC24V
Standby current	110 μ A
Alarm current	L-C: 65mA, P-C: 50mA
Sensing length	25m - 35m
Sensor viewing angle	100°(±50°)
Alarm indicator	OMNIVIEW 360°
Sensing method	Dual infrared wavelength
Operating temperature	-10°C to +50°C
Material	PC: Polycarbonate
Weight	180g(with Base)
Connectable fire alarm panel	Conventional: 1PM, 2PD, 1PV Addressable: NFU-7000/7000-L
Optional Accessory	MTE: Flame detector Testing Device

■ Ordering Information

Adjustable mounting bracket
FKD-90



Sunshade
RD-14



All specifications are subject to change without any notice.
For more information, contact with NITTAN.

NITTAN

54-5, 1-chome, Sasazuka,
Shibuya-ku, Tokyo151-8535, Japan
TEL:81-3-5333-7021 FAX:81-3-5333-8615

Distributed By