

### ■ Features

- Conventional fire alarm bell
- 150mm (6 inch)
- Explosion Proof Exd II BT4
- IP 54

### ■ Specifications

Specifications	EMB-6
Approval Number	13-4
Explosion Proof Class	Exd II BT4
IP Rating	IP54
Rated Voltage	24 VDC (19.2 to 28.8 VDC)
Rated Current	15 mA
Sound Output	90 dB at 1 m
Operating Temperature	- 20°C to + 60°C
Environmental Humidity	35 % to 95 % Rh
Finish Color (Gong)	Munsell Code 7.1R3.6/12.8
Weight	3 kg

### ■ Dimensions

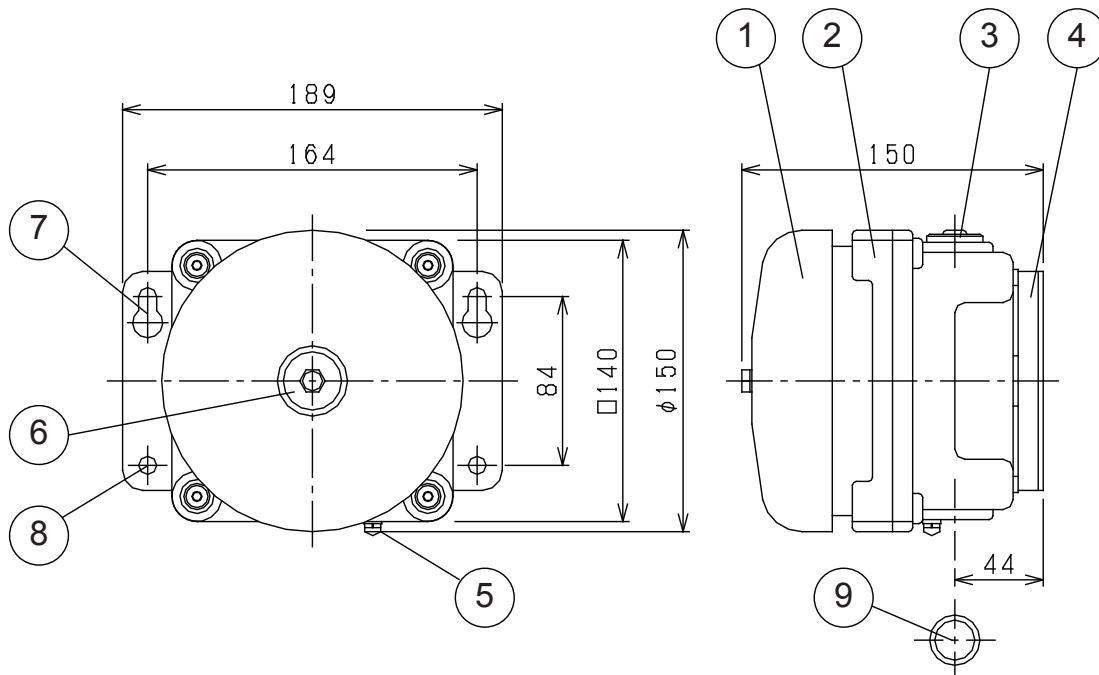

- |                   |                     |                  |         |
|-------------------|---------------------|------------------|---------|
| 1. Gong           | Aluminum Diecasting | 6. Name Plate    |         |
| 2. Housing        | Aluminum Diecasting | 7. Mounting Hole | φ9, φ15 |
| 3. Plug           | Aluminum Diecasting | 8. Mounting Hole | φ9      |
| 4. Mounting Base  | SPCC                | 9. Wiring Outlet | G1/2    |
| 5. Earth Terminal | M4 Screw            |                  |         |