

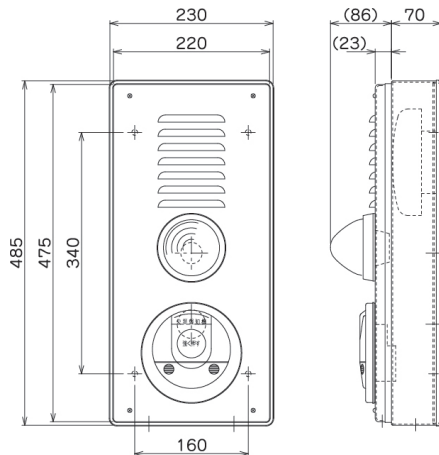

■ Features

- Equipped with alarm bell, indication lamp and manual call point
- Weather-proof type
- Vertical-mount type
- Easy installation and cable wiring by Built-in terminal block
- Surface and recessed mountings are available

■ Drawings



SRTW-01M6L-47SD
SRTW-02M6L-47SD

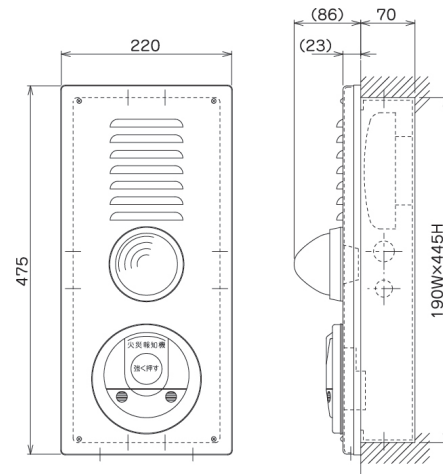

SUTW-01M6L-47SD
SUTW-02M6L-47SD

■ Specifications

Specifications		SRTW-01M6L-47SD	SRTW-02M6L-47SD	SUTW-01M6L-47SD	SUTW-02M6L-47SD
Mounting Type		Vertical, Surface	Vertical, Surface	Vertical, Recessed	Vertical, Recessed
Weather Proof		✓	✓	✓	✓
Telephone Jack		✓	N/A	✓	N/A
Accessories	Alarm Bell	BD-6-24-11			
	Indication Lamp	PL-R4-LED			
	Manual Call Point	1MI1A	2MH1A	1MI1A	2MH1A
	Surface Mounting Box	SRTW-47-06	SRTW-47-06	N/A	N/A
	Recessed Mounting Box	N/A	N/A	SU-445-03	SU-445-03
Plate Cover, Push Button		Japanese indication *Modifiable to English version			
Operating Temperature		-0°C to +50°C			
Box Material		Steel			
Weight c/w Box		5.5 kg	5.5 kg	4.7 kg	4.7 kg