



1PM2

■ Description

The 1PM2 is a conventional fire alarm panel with a stylish wall-mount design supplied in 10 to 60 zone formats. All detector circuits will be indicated with lighting red LEDs in alarm conditions and flashing in open circuit fault conditions. Slide-in paper labels are included for clear zone identification. The alarm panel has an alarm delay function on every detector circuits to reduce false alarms, including a zone-by-zone settable delay ON/OFF function.

1PM2 features a re-sounding function of panel buzzer by reception of any subsequent input from manual alarm stations or other zones ensuring an announcement of a fire spread after the buzzer silenced. The alarm panel also has a maintenance switch to enable installation or maintenance works to cut off the panel buzzer and zone alarms.

1PM2 to be equipped with a CPU for securing high reliability features also a CPU trouble back-up function. Even when the CPU falls down, basic functions are secured to indicate alarm zones, to sound alarms and to transmit the alarm signal.

The power consumption reduced 70% compared with Nittan's previous models contributes to cost reduction.

■ Features

- 10 to 60 zone model available
- Extra slim design
- Highly reliable design by adopting durable LED indicators and CPU
- 10 to 20 circuits for zone alarm bells available (depends on the model on purchased)
- Alarm delay function
- Alarm delay ON/OFF switch function
- Trouble monitoring function
- CPU trouble back-up function
- Re-sounding mode of a panel buzzer
- Equipped with high protection for Lightning surge
- Interrupting function for emergency announcements to silence zone alarms
- 3 alarm indicators for indicating the alarm inputs from building facilities such as hydrants
- CPU trouble back-up function
- Capability of transmitting the second fire signal
- Signal transmit for Emergency PA facility also equipped
- Easy wiring by Push-in terminals' one-touch connection

■ Remote Test Function

Remote test function is available on 2KAH3-P and 2KAD3-P detectors etc. with a dedicated testing device.



* Operating Image

2KAH3-P

- Distinguishes steam and smoke
- Automatic sensitivity compensation
- Suitable for Shower rooms and Kitchens



2KAD3-P

- Remote-test available
- Automatic sensitivity compensation
- Suitable for Condominiums

■ Main Features

1. High reliability, advanced fire detection

Re-sounding mode of panel buzzer



After Panel alarm silence by operator at fire, the panel buzzer automatically re-sounds by operation of manual alarm stations or by receipt of alarm signal from other zones to announce fire spread.

CPU trouble back-up function

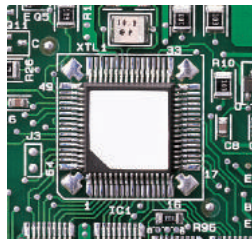

Even when CPU is down, basic function is carried on, fire signal can be received, zone indication, alarm sounding, fire alarm signal transmission, etc.

Alarm delay ON/OFF function

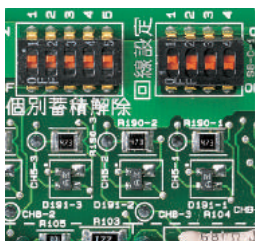

Alarm delay function can be cancelled zone by zone individually.

Outputs for Emergency PA system

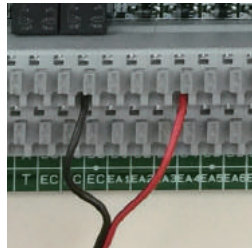

Outputs for interlocking to Emergency PA system are provided as standard.

2. Advanced functions for easy installation and maintenance

Lightning surge protection

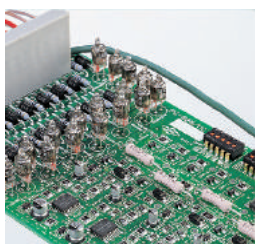

Lightning surge protection devices are provided as standard to main circuits to protect semiconductor parts.

Maintenance switch (All alarm silence)

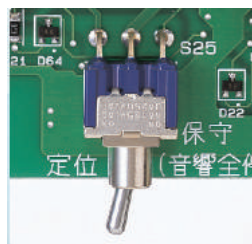

At maintenance work, unnecessary alarm sounding can be cut off by operating the maintenance switch (except telephone calling sound). Clicking sounds is made when the maintenance switch is ON to draw operator's attention.

Alarm delay ON/OFF switch



This switch can make the alarm delay function ineffective for installation and maintenance work.

Push-in type terminals

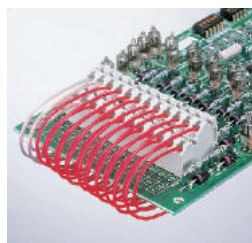

Push-in type terminals are employed to improve efficiency at installation.

Auto reset switch

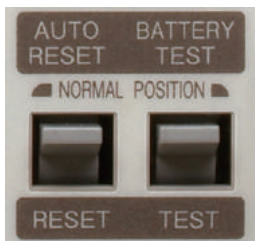

When operation test of detectors and manual alarm stations are conducted, by pressing auto reset switch to the reset side, fire test can be conducted zone by zone and the tested detector and the control panel shall be automatically reset.

Self-checking function

- Monitoring;
- Detector line open-circuit
 - Circuit voltage low
 - CPU trouble
 - Fuse blow
 - Disconnection of Standby battery
 - Emergency PA line open-circuit

■ Indicators on Operation Panel

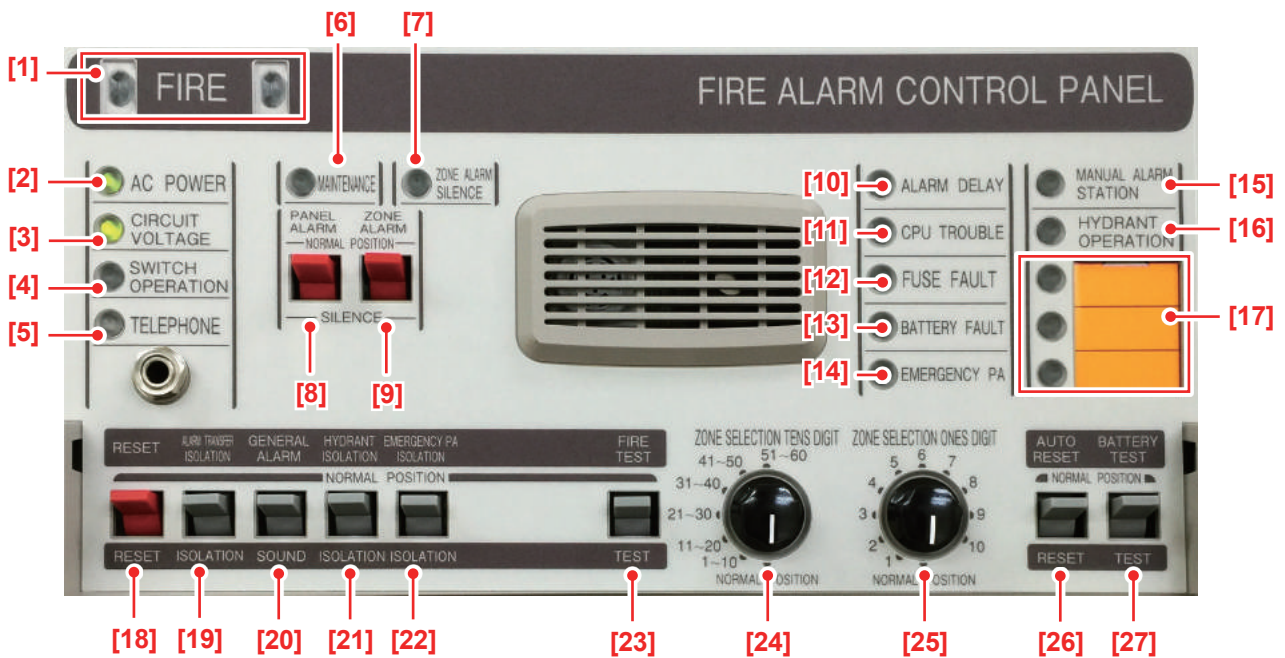

- [1] FIRE (Red)**
LED turns on when the panel is in an alarm condition.
- [2] AC POWER (Green)**
LED turns on when AC power is supplied to the main power circuit.
- [3] CIRCUIT VOLTAGE (Green)**
LED turns on as long as the main circuit voltage of the control panel is within acceptable levels (approx. 20.4 V and greater).
- [4] SWITCH OPERATION (Red)**
LED flashes when the panel switches are ON or not normal state.
- [5] TELEPHONE (Green)**
LED turns on when a handset is plugged into a telephone jack of a manual alarm station or an annunciator panel.
- [6] MAINTENANCE (Red)**
LED turns on during a maintenance mode.
- [7] ZONE ALARM SILENCE INDICATOR (Red)**
LED flashes when zone alarms are silenced.
- [8] PANEL ALARM SILENCE switch**
Activation of this switch when a panel buzzer is sounding, turns off the sounding buzzer.
- [9] ZONE ALARM SILENCE switch**
Activation of this switch makes zone alarms silenced.
- [10] ALARM DELAY (Red)**
LED turns on during a delay time of 60 sec, and flashes during a general alarm delay switch is OFF.
- [11] CPU TROUBLE (Red)**
LED turns on when the CPU is in a fault state.
- [12] FUSE FALUT (Red)**
LED turns on when a fuse for zone alarm outputs is blown.
- [13] BATTERY FAULT (Red)**
LED turns on when a standby battery is not connected to the panel.
- [14] EMERGENCY PA (Red)**
LED flashes during emergency PA announcements, and turns on when an open circuit is detected on the emergency PA lines.
- [15] MANUAL ALARM STATION (Red)**
LED turns on when a manual alarm station is activated.
- [16] HYDRANT OPERATION (Red)**
LED flashes while a hydrant pump(s) is in operation.
- [17] Other Alarms (Red)**
Each of the LEDs turns on when the panel receives alarm signals from building facilities via LXn-C contacts.
- [18] RESET switch**
Activation of this switch resets the panel condition.
- [19] ALARM TRANSMISSION ISOLATION switch**
Activation of this switch isolates an alarm signal transmission through GA-GB-GC contacts.
- [20] GENERAL ALARM switch**
Activation of this switch activates all the zone alarms and outputs alarm signals to an emergency PA facility.
- [21] HYDRANT STATION ISOLATION switch**
Activation of this switch isolates an alarm signal transmission through H-H' contacts.
- [22] EMERGENCY PA ISOLATION switch**
Activation of this switch isolates an alarm signal transmission to an emergency PA facility.
- [23] FIER TEST switch**
Use this switch for conducting a fire indication test.
- [24] ZONE SELECTION TENS DIGIT switch**
This switch sets tens digit of testing zones during a fire indication test.
- [25] ZONE SELECTION ONES DIGIT switch**
This switch sets ones digit of testing zones during a fire indication test.
- [26] AUTO RESET switch**
Activation of this switch enables a non-latching test function which allows manual alarm stations and detectors to be tested and the panel to resets automatically.
- [27] BATTERY TEST switch**
Activation of this switch enables a standby battery test.

Typical Wiring Diagram

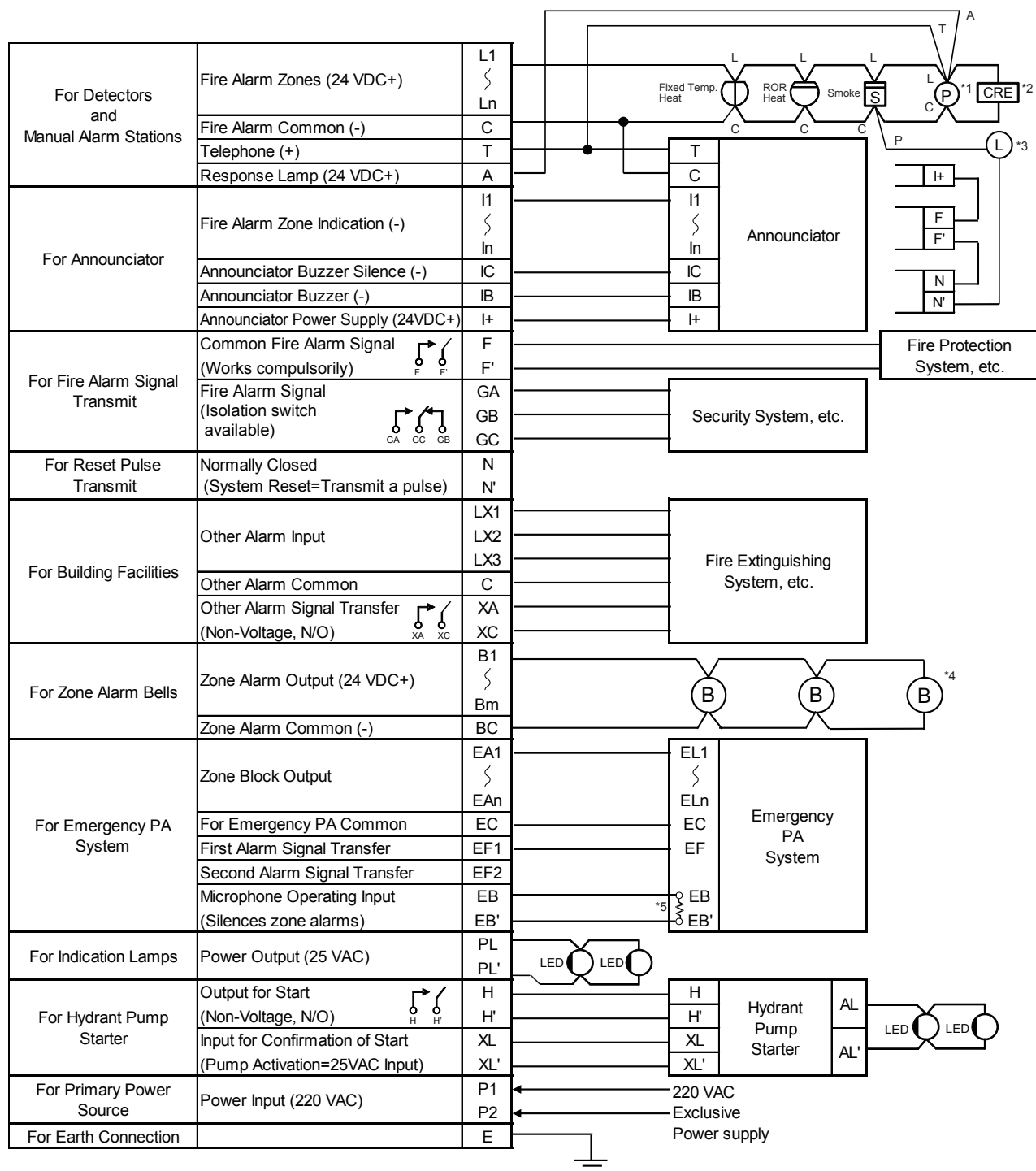

*1: P = Manual Alarm Station

*2: The CRE is a dedicated end-of-line device which comes with the 1PM2 fire alarm control panel.

*3: Make sure to be used F-F' and N-N' terminals when use Remote indication lamps.

*4: Use the motor bells rated at 10 mA, 24 VDC.

*5: The end-of-line resistor comes with the 1PM2 fire alarm control panel.

■ Dimensions

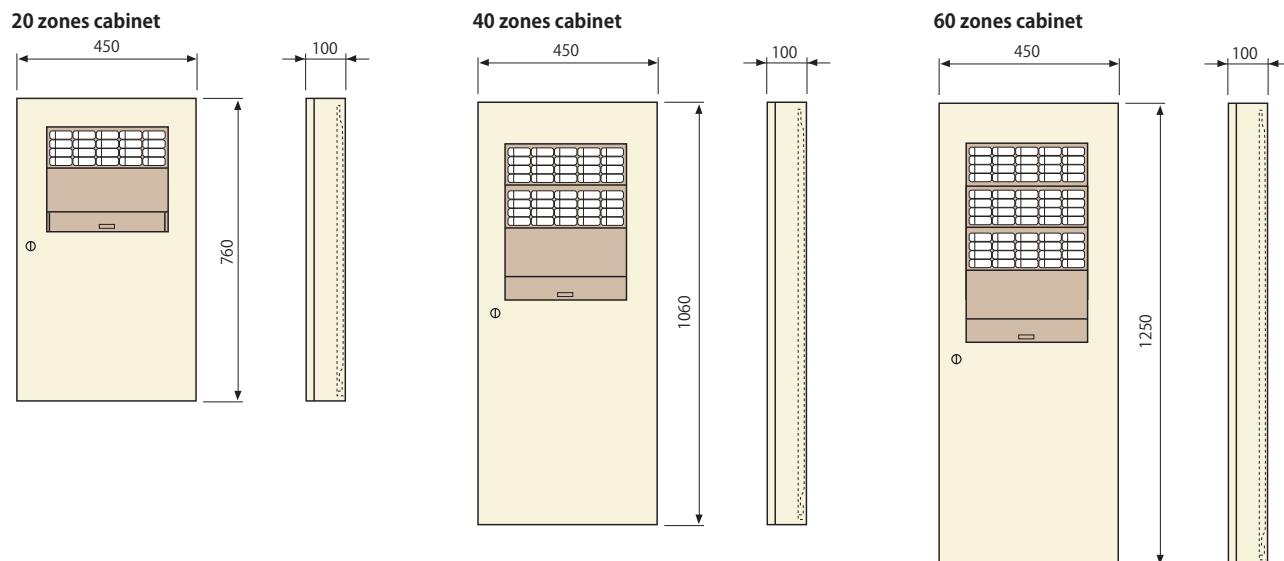

Specifications	1PM2-nLA					
Number of Zones	10	20	30	40	50	60
Number of Bells (10 mA)	20			30		
Number of Bell Blocks	10	15			20	
Primary Rated Current (220VAC)	0.39 A					
Standby Battery	0.45 Ah			1.2 Ah		
Mounting Type	Wall-mounting type					
Dimensions (mm)	W 450 x H 760 x D 100		W 450 x H 1060 x D 100		W 450 x H 1250 x D 100	
Weight	18 kg		25 kg		30 kg	
Notes	Not included: Dedicated Battery, Telephone Handset					

■ Ordering Information

Model	Description
PTL-1	Telephone Handset
Nicd-battery (0.45AH)	Ni-Cd Battery (0.45AH) for 1PM2-10LA – 30LA
Nicd-battery (1.2AH)	Ni-Cd Battery for (1.2AH) for 1PM2-40LA – 60LA
PSH-nL	Annunciator Panel with n Zone
2KH2-LS	Optical Smoke Detector
CKLD-KPT	Beam Type Smoke Detector
LP05	Remote Station for Beam Detector
1CD-70-LS	Fixed Temp. Heat Detector, 70°C
2SC-LS	Rate of Rise Heat Detector
2KAH3-P	Dual Wavelength Type Optical Smoke Detector with Remote testing function
2KAD3-P	Optical Smoke Detector with Automatic sensitivity compensation and Remote testing function
MTS2	Remote Testing and Address Setting Device for 2KAH3-P, 2KAD3-P and others
LP01/1	Remote Station for MTS2
3T	Common detector Base for LS type detector
B6T2	Common detector Base for LS type detector for connecting a remote indication lamp
B3-J	Detector Base for 2KAH3-P, 2KAD3-P, and others
1MF1A	Manual Alarm Station with telephone jack
BD-6-24-11	Local Alarm Bell (10 mA)
PL-R4-LED	Indication Lamp (LED type)
AL-4-24	Remote Indication Lamp
SRT-01M6L-47SGB	Local Combined Box (vertical type) with telephone jack c/w Surface Mounting Box

■ Specifications

Specifications	1PM2-nLA																								
AC Power	220 VAC ±10% 50/60 Hz																								
Standby Battery	Sealed Type Ni-Cd battery 10LA - 30LA Panel : 0.45 Ah 40LA - 60LA Panel : 1.2 Ah																								
Power Consumption	39 VA																								
Nominal Delay Time	60 sec. (For smoke detector: 60 sec. For heat detector: 20 sec.)																								
Dimensions	10L - 20L Panel : W 450 x H 760 x D 100 mm 30L - 40L Panel : W 450 x H 1060 x D 100 mm 50L - 60L Panel : W 450 x H1250 x D 100 mm																								
LED Indicators	Fire alarm, AC power, Circuit voltage, Switch operation, Telephone, Maintenance, Zone alarm silence, Alarm delay, CPU trouble, Fuse fault, Battery fault, Emergency PA, Manual alarm station, Hydrant operation, Other alarm (3 windows)																								
Functions	CPU fault monitoring, Fuse fault indication, Cable break monitoring																								
External Line Resistance	50 Ω and less																								
End of Line Device	CRE																								
Panel Alarm Sounder	Piezoelectric buzzer, automatic re-sounding type																								
Trouble Alarm	Detector line open-circuit, CPU trouble, Zone Alarm Fuse blows, No battery connected, Emergency PA line open-circuit, Alarm inputs from external equipment																								
Fire Alarm Transmission	<table border="0"> <tr> <td></td> <td></td> <td>Contact Capacity</td> </tr> <tr> <td>Common Fire Alarm</td> <td>: F-F' (Normally-Open)</td> <td>1 A 24 VDC</td> </tr> <tr> <td>Fire Alarm</td> <td>: GA-GB-GC (Form-C)</td> <td>1 A 24 VDC</td> </tr> <tr> <td>Reset Pulse</td> <td>: N-N' (Normally-Close)</td> <td>1 A 24 VDC</td> </tr> <tr> <td>External Equipment Alarms</td> <td>: XA-XC</td> <td>1 A 24 VDC</td> </tr> <tr> <td>Emergency PA</td> <td>: EC EF1 EF2 EA1-EAn* EB EB'</td> <td>1 A 24 VDC</td> </tr> <tr> <td></td> <td>(Normally-Open)</td> <td>1 A 24 VDC</td> </tr> <tr> <td></td> <td>*n: 10LA=10, 20LA-40LA=15, 50LA-60LA=20</td> <td></td> </tr> </table>			Contact Capacity	Common Fire Alarm	: F-F' (Normally-Open)	1 A 24 VDC	Fire Alarm	: GA-GB-GC (Form-C)	1 A 24 VDC	Reset Pulse	: N-N' (Normally-Close)	1 A 24 VDC	External Equipment Alarms	: XA-XC	1 A 24 VDC	Emergency PA	: EC EF1 EF2 EA1-EAn* EB EB'	1 A 24 VDC		(Normally-Open)	1 A 24 VDC		*n: 10LA=10, 20LA-40LA=15, 50LA-60LA=20	
		Contact Capacity																							
Common Fire Alarm	: F-F' (Normally-Open)	1 A 24 VDC																							
Fire Alarm	: GA-GB-GC (Form-C)	1 A 24 VDC																							
Reset Pulse	: N-N' (Normally-Close)	1 A 24 VDC																							
External Equipment Alarms	: XA-XC	1 A 24 VDC																							
Emergency PA	: EC EF1 EF2 EA1-EAn* EB EB'	1 A 24 VDC																							
	(Normally-Open)	1 A 24 VDC																							
	*n: 10LA=10, 20LA-40LA=15, 50LA-60LA=20																								
Output Current for Zone Alarms (Bell)	24 VDC 10LA-30LA: 200 mA 40LA-60LA: 300 mA																								
Output Current for Indication Lamps	25 VAC 400 mA																								
Number of Connectable Detectors	<table border="0"> <tr> <td>Standard type</td> <td>Smoke detector:</td> <td>Max. 40 /zone, Total 20 x zones</td> </tr> <tr> <td></td> <td>Heat detector:</td> <td>As required</td> </tr> <tr> <td>Thermistor type</td> <td>Heat detector:</td> <td>Max. 24 /zone, Total 12 x zones</td> </tr> <tr> <td>Detectors with test function:</td> <td></td> <td>Max. 20 /zone, Total 10 x zones</td> </tr> </table>	Standard type	Smoke detector:	Max. 40 /zone, Total 20 x zones		Heat detector:	As required	Thermistor type	Heat detector:	Max. 24 /zone, Total 12 x zones	Detectors with test function:		Max. 20 /zone, Total 10 x zones												
Standard type	Smoke detector:	Max. 40 /zone, Total 20 x zones																							
	Heat detector:	As required																							
Thermistor type	Heat detector:	Max. 24 /zone, Total 12 x zones																							
Detectors with test function:		Max. 20 /zone, Total 10 x zones																							
Connectable Manual Alarm Station	1MF1A 1MI1A																								
Connectable Annunciator Panel	Model PSH x 1 unit																								
Operating Temperature	0°C to +40°C																								
Primary Materials	Main Body: SPCC t1.6 Door: SPCC t1.2 Operation Panel: Flame retardant resin																								
Body Color	JPMA Color Code A22-90B Semi-gloss (off-white)																								

All specifications are subject to change without any notice.
For more information, contact with NITTAN.

NITTAN

54-5, 1-chome, Sasazuka,
Shibuya-ku, Tokyo151-8535, Japan
TEL:81-3-5333-7021 FAX:81-3-5333-8615

Distributed By